

HEEL GUARD NON-SLIP GALVANISED GRATE AND FRAME

450X450 HEAVY DUTY

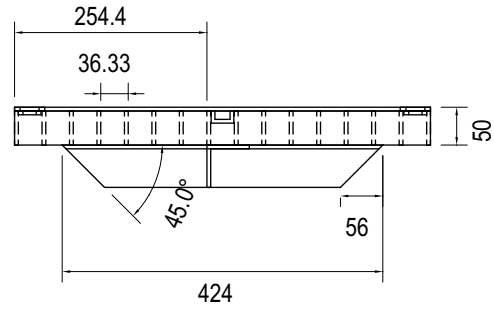
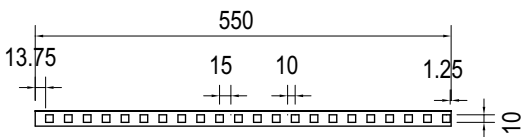
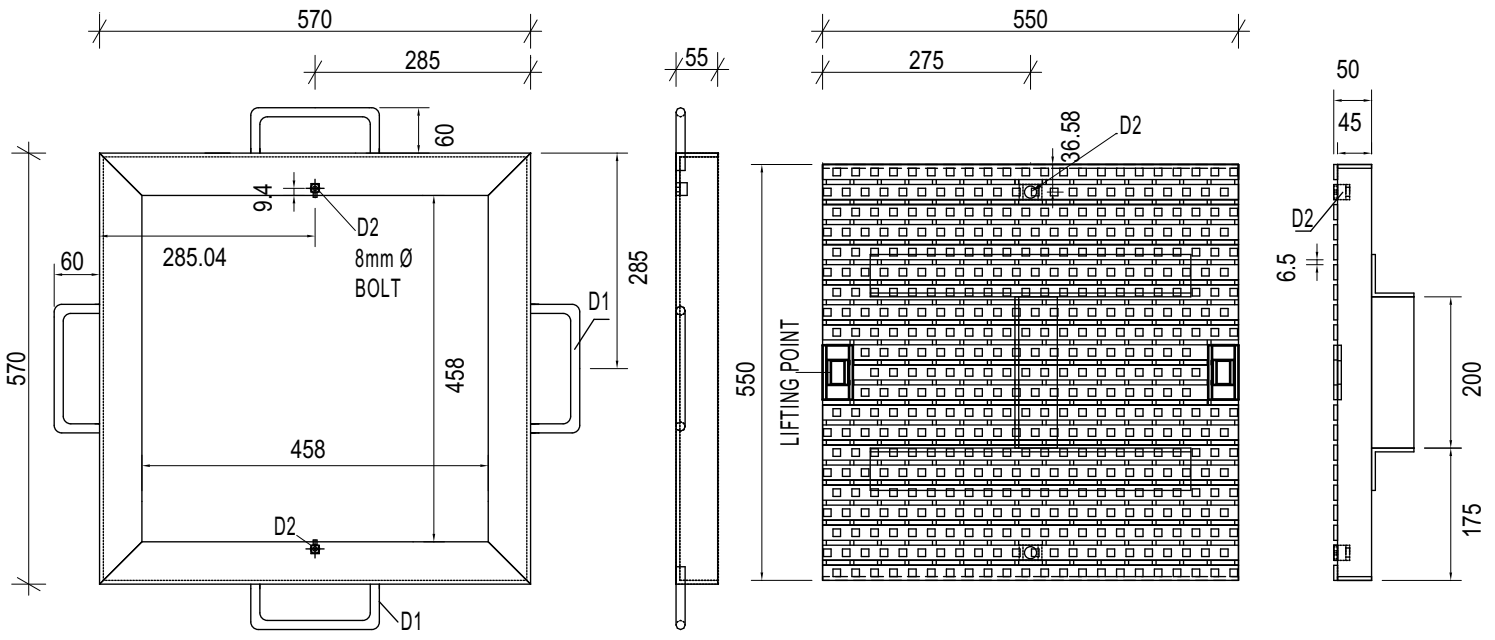

NON SLIP FLAT BAR DETAIL

GRATE SECTION DETAIL

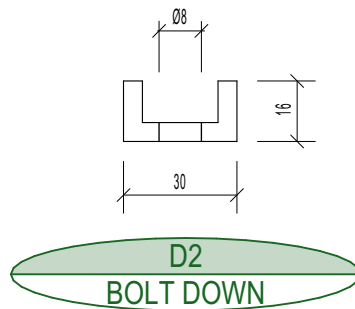
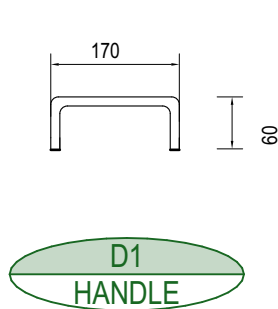

MATERIAL MILD STEEL
 FINISH HOT DIP GALVANISED TO AS1650
 MASS 31kg approx.

SLIP RESISTANCE CLASSIFICATION TO AS4586-2013
 CERTIFIED 13 NOV. 2020
 NATA ACCREDITATION NO. 14967

P4

GRATE & FRAME - HEEL GUARD

Product Code: HG45D

ALL DIMENSIONS IN MILLIMETRES
 (NOT TO SCALE)

9 COLEMANS ROAD
 DANDENONG SOUTH VIC. 3175
 03 9786 3111
 sales@frankstonconcrete.com.au
 www.frankstonconcrete.com.au

