

# 1100 Litre NEAUTRALISING TANK

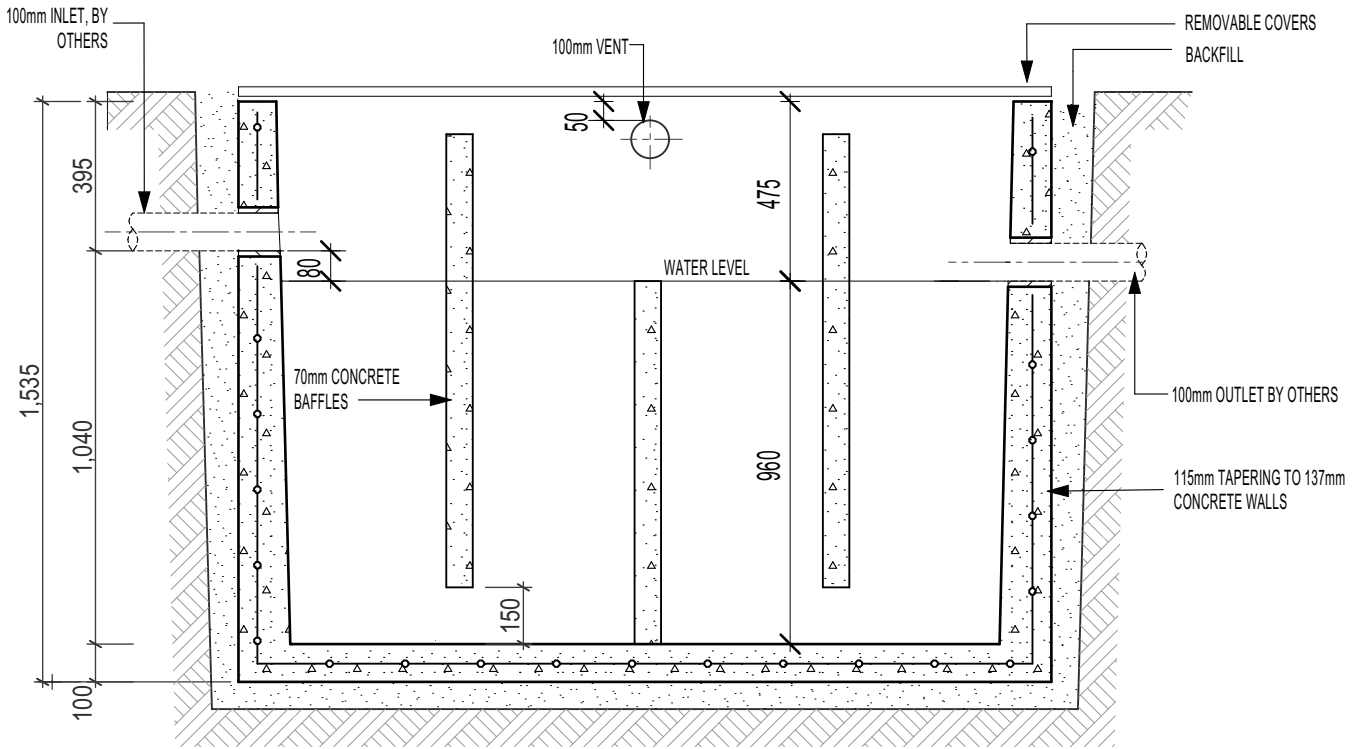

## SECTION A-A

CONCRETE 28 days 40mpa  
 Penetron Admix®  
 SB Alkaline Mix  
 REINFORCEMENT F72  
 LIFTERS 4 x 2.5 t

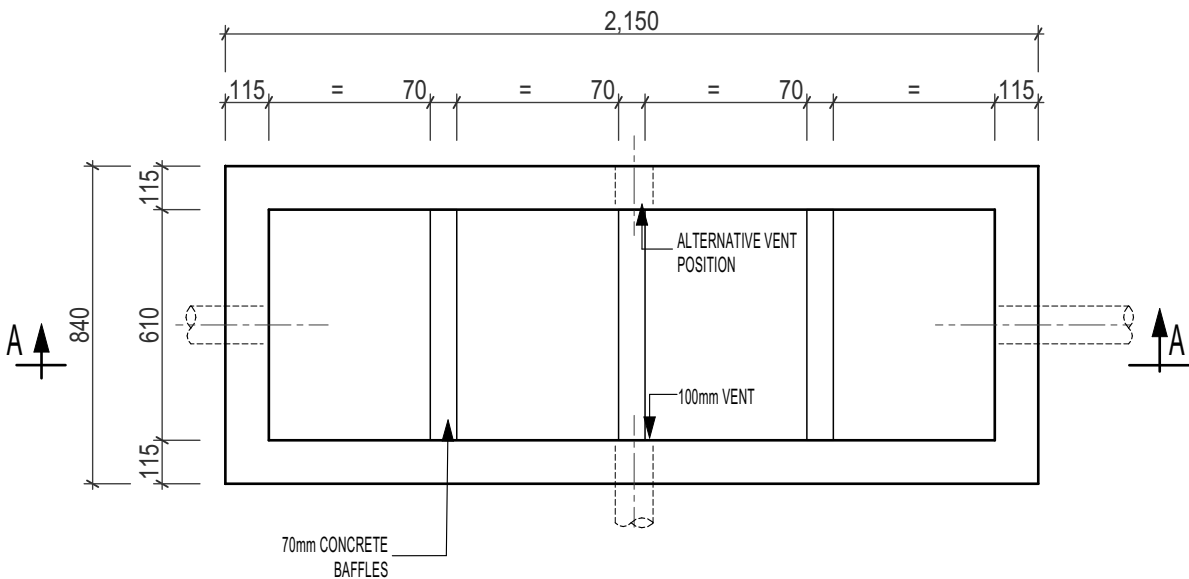

## PLAN

CAST IRON ACCESS  
 COVERS TO SUIT:  
 - LIGHT DUTY (55MM) OR  
 - HEAVY DUTY (100MM)

EXTENSION RISERS MADE  
 TO REQUIRED DEPTH. MIN.  
 HEIGHT 300MM.

WEIGHT 3070KG

54 X 20KG MARBLE CHIPS REQUIRED, SOLD SEPARATELY.

INTERCEPTOR TO BE  
 INSTALLED, CONNECTED,  
 VENTED & PROVIDED WITH  
 COVERS IN ACCORDANCE  
 WITH LOCAL AUTHORITY.



9 COLEMANS ROAD  
 DANDENONG SOUTH VIC.  
 3175

03 9786 3111  
 sales@frankstonconcrete.com.au  
 www.frankstonconcrete.com.au

SKU NP1100

ALL DIMENSIONS IN MILLIMETRES  
 (NOT TO SCALE) DRAWN: CZ  
 ISSUE: MAY 2023