

Pump Well Tank - 1200 dia x 1900 deep - 2100 Litres

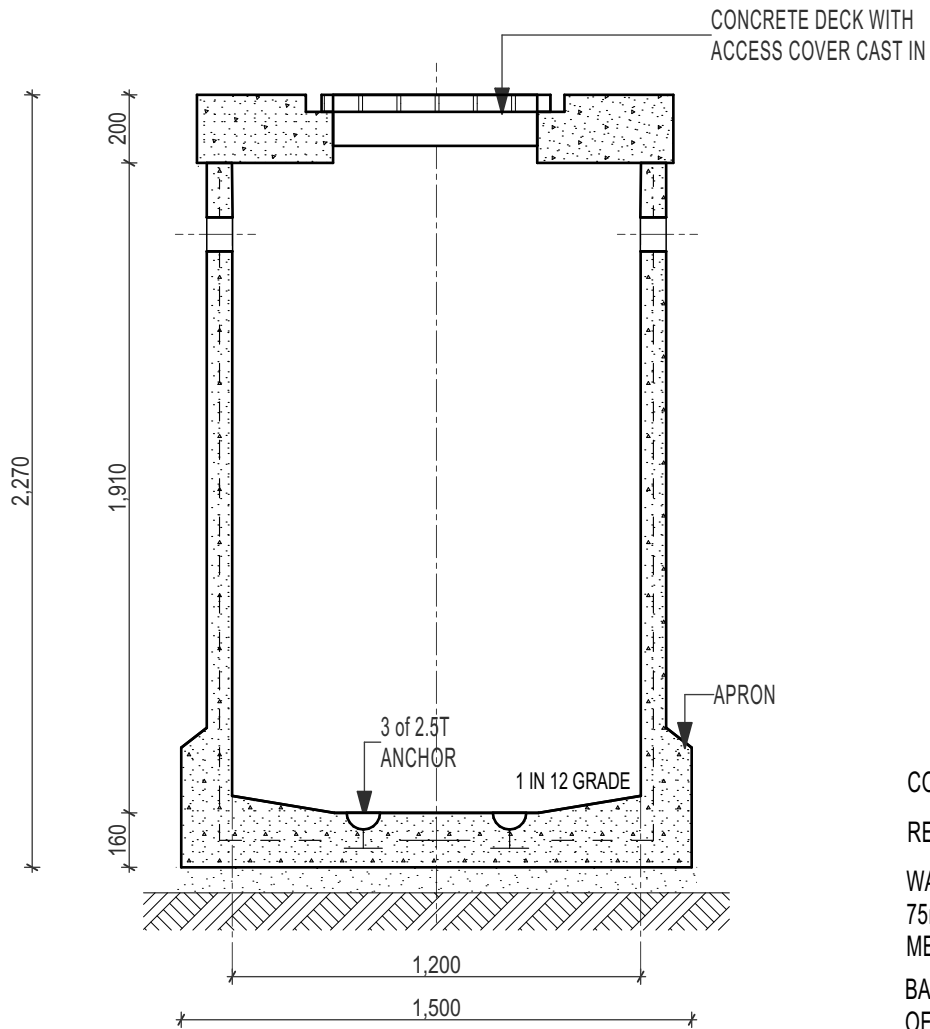

CONCRETE 40MPa 28 days.
 REINFORCEMENT
 WALLS:
 75mm CONC. WITH F41 MESH CENTRALLY LOCATED
 BASE: 160mm WITH 1x LAYER OF F41 MESH & 1x F72

SECTION A-A

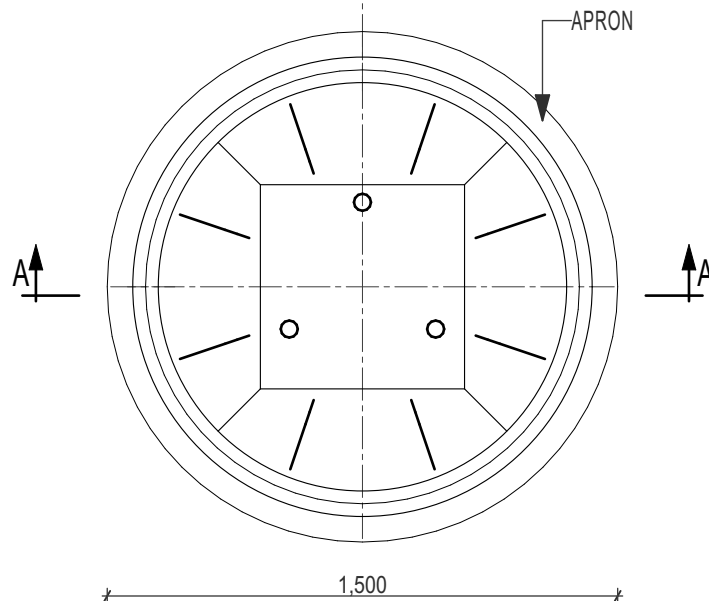

PITS TO BE INSTALLED, CONNECTED, VENTED & PROVIDED WITH COVERS IN ACCORDANCE WITH LOCAL AUTHORITY.

EXTENSIONS TO BE CONNECTED TO EXISTING UNIT WITH APPROVED MASTIC SEAL.

COVERS AVAILABLE IN SQUARE OR CIRCULAR SLAB CONFIGURATION.

COVER LOCATION & SIZE SPECIFIED MUST BE SUITABLE TO ACCOMMODATE PUMP REMOVAL

AVAILABLE WITH SEALED LID OR GRATE LIGHT, MEDIUM or HEAVY DUTY

PLAN



9 COLEMANS ROAD
 DANDENONG SOUTH VIC.
 3175

03 9786 3111
 sales@frankstonconcrete.com.au
 www.frankstonconcrete.com.au

SKU PW1200

ALL DIMENSIONS IN MILLIMETRES (NOT TO SCALE) DRAWN: CZ
 ISSUE: MAY 2023