

Pump Well Tank - 1500 dia x 2000 deep - 3500 Litres

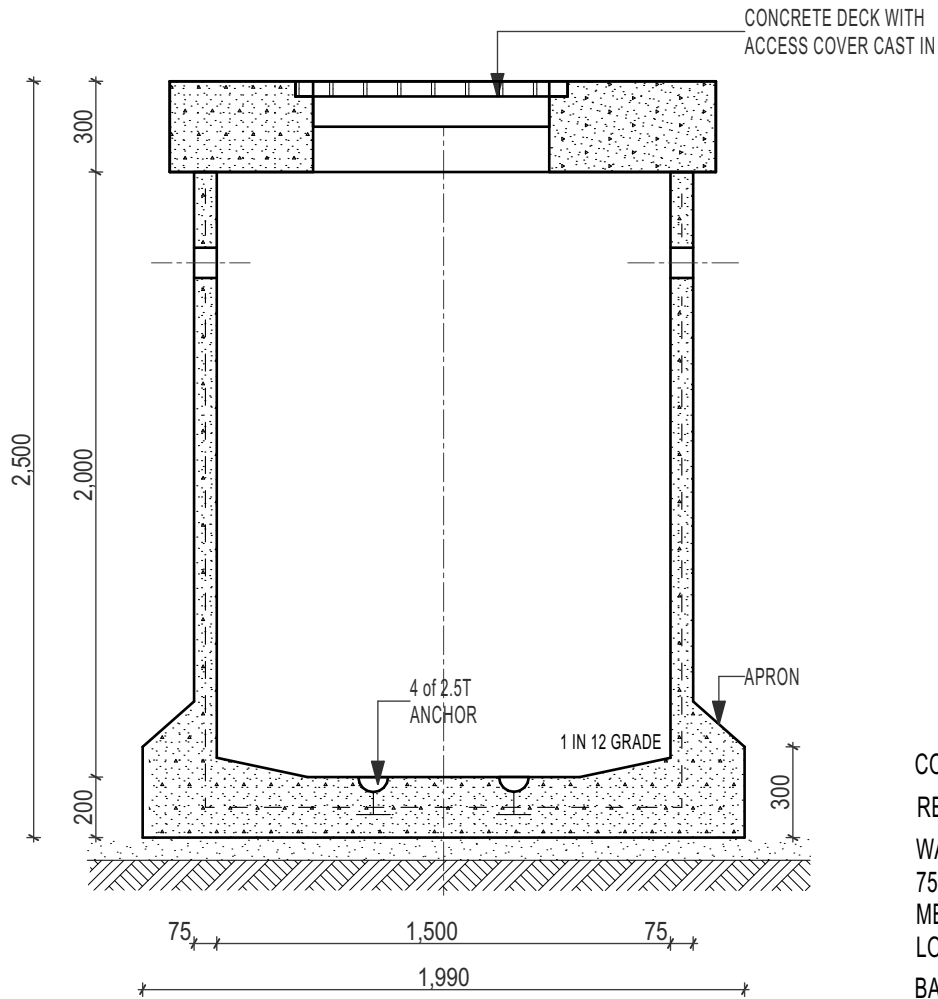

SECTION A-A

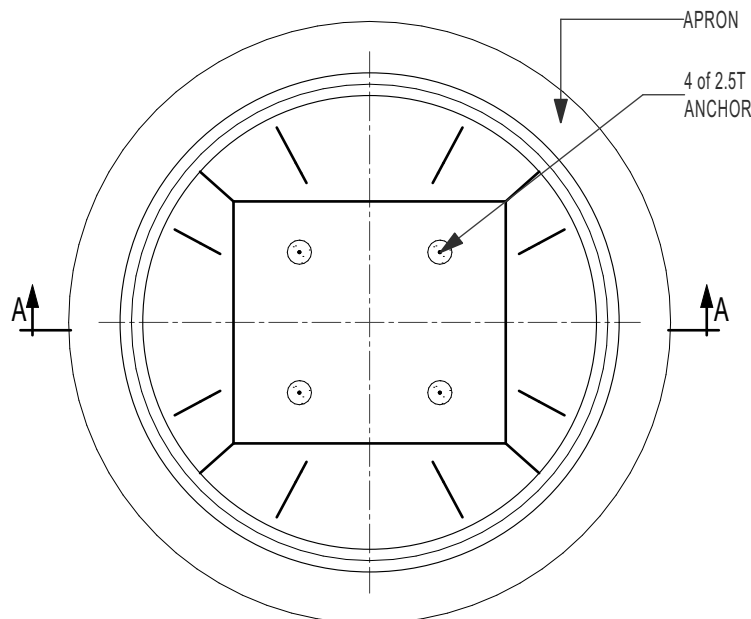

PLAN

WEIGHT(approx.) BASE 4500 kgs - LID - 2000kg

CONCRETE 40MPa 28 days.
 REINFORCEMENT
 WALLS:
 75mm CONC. WITH F41
 MESH CENTRALLY
 LOCATED
 BASE: 200mm WITH 1xLAYER
 OF F41 MESH & 1x F72

PITS TO BE INSTALLED,
 CONNECTED, VENTED &
 PROVIDED WITH COVERS
 IN ACCORDANCE WITH
 LOCAL AUTHORITY.

EXTENSIONS TO BE
 CONNECTED TO EXISTING
 UNIT WITH APPROVED
 MASTIC SEAL.

COVERS AVAILABLE IN
 SQUARE OR CIRCULAR
 SLAB CONFIGURATION.

COVER LOCATION & SIZE
 SPECIFIED MUST BE SUITABLE
 TO ACCOMODATE PUMP
 REMOVAL

AVAILABLE WITH SEALED LID
 OR GRATE LIGHT, MEDIUM or
 HEAVY DUTY



9 COLEMANS ROAD
 DANDENONG SOUTH VIC.
 3175

03 9786 3111
 sales@frankstonconcrete.com.au
 www.frankstonconcrete.com.au

SKU PW1500

ALL DIMENSIONS IN MILLIMETRES (NOT TO SCALE) DRAWN: CZ
 ISSUE: MAY 2023