

4000 Litre TYPE A RECLAIM PIT

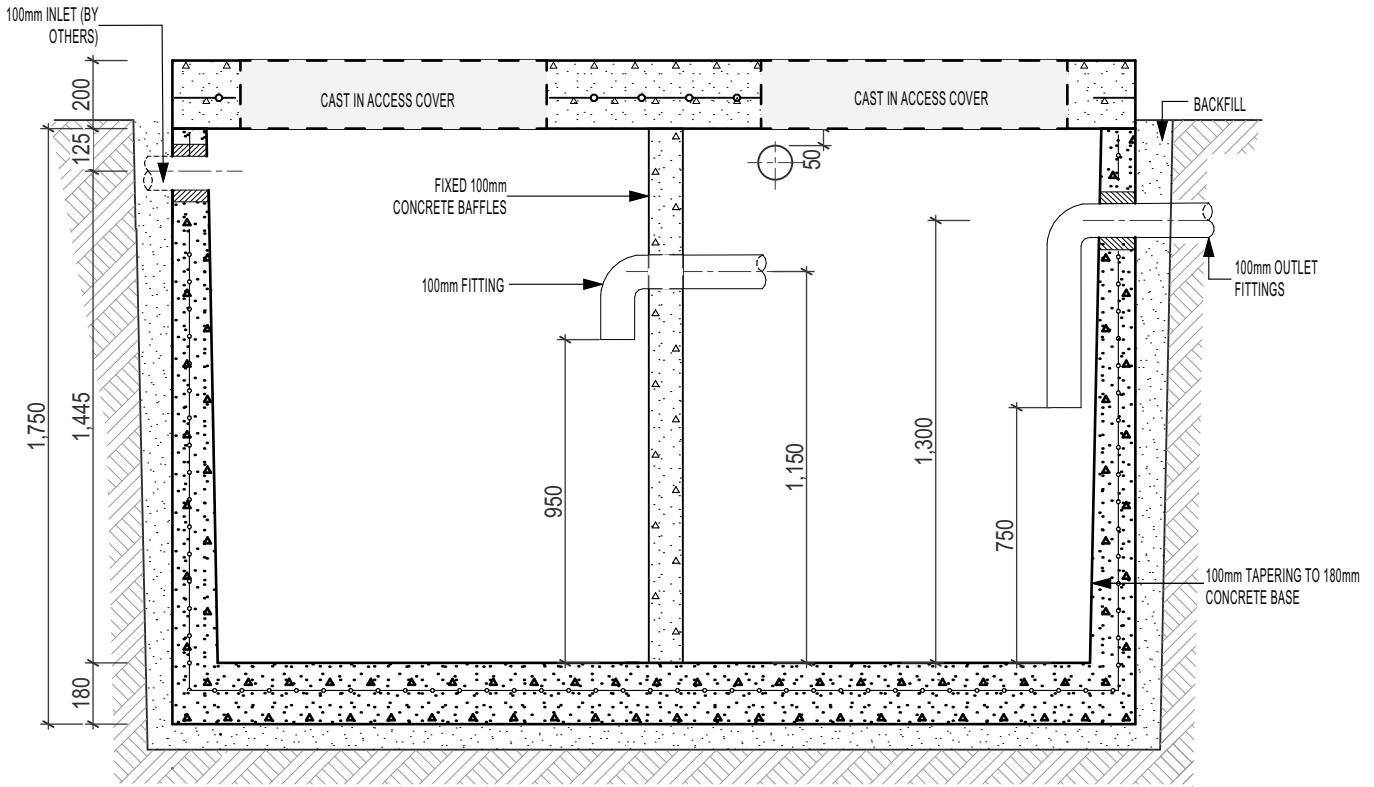

SECTION A-A

CONCRETE 28 days 40mpa
 REINFORCEMENT F72
 LIFTERS 4 x 5 t

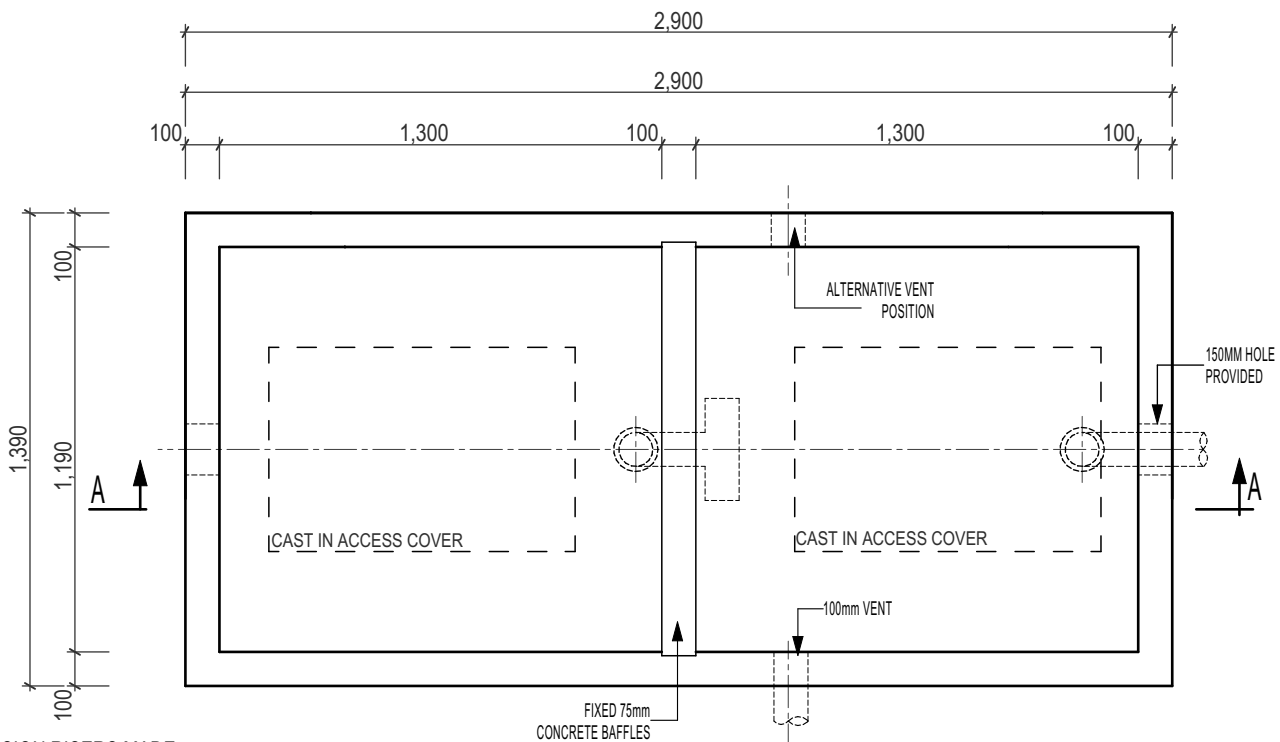

PLAN

WEIGHT 7000KG

EXTENSION RISERS MADE TO REQUIRED DEPTH. MIN. HEIGHT 300MM.

200MM CONCRETE DECKS WITH CAST IN ACCESS COVERS AS REQUIRED - LIGHT OR HEAVY DUTY -

INTERCEPTOR TO BE INSTALLED, CONNECTED, VENTED & PROVIDED WITH COVERS IN ACCORDANCE WITH LOCAL AUTHORITY.



9 COLEMANS ROAD
 DANDENONG SOUTH VIC.
 3175

03 9786 3111
 sales@frankstonconcrete.com.au
 www.frankstonconcrete.com.au

SKU TW4000A

ALL DIMENSIONS IN MILLIMETRES (NOT TO SCALE) DRAWN: CZ
 ISSUE: JUNE 2023