

600 x 600 Stormwater Pit

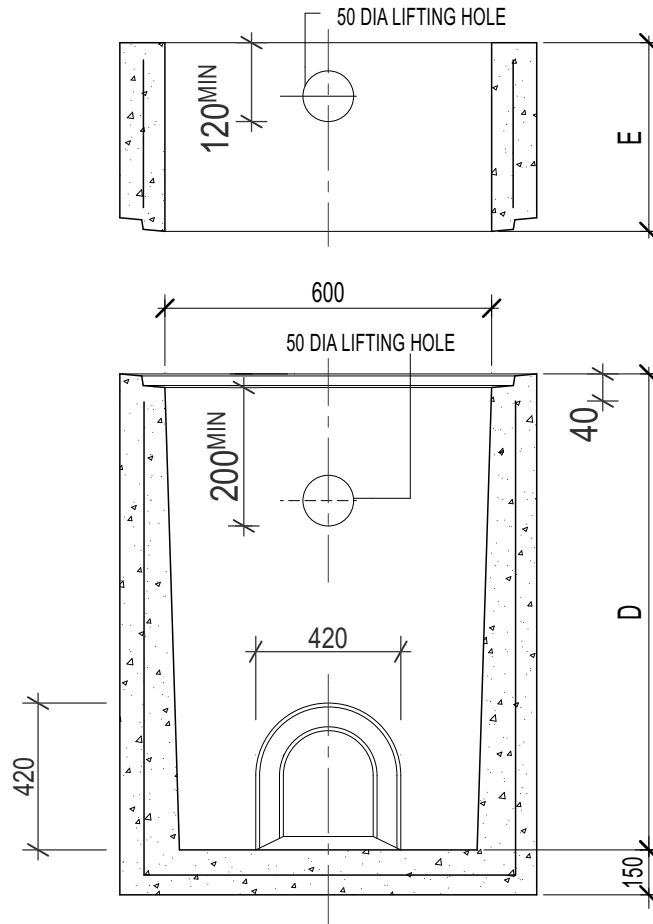

SECTION A-A

MANUFACTURE METHOD	WET CAST
CONCRETE	40Mpa
REINFORCEMENT	F72
LIFTERS	2 x 1.3t

KNOCKOUTS
PROVIDED ON ALL SIDES

- AVAILABLE COVERS
- CONCRETE
 - CAST IRON
 - MILD STEEL GRATING
 - HEEL SAFE GRATES
 - TERRA FIRMA

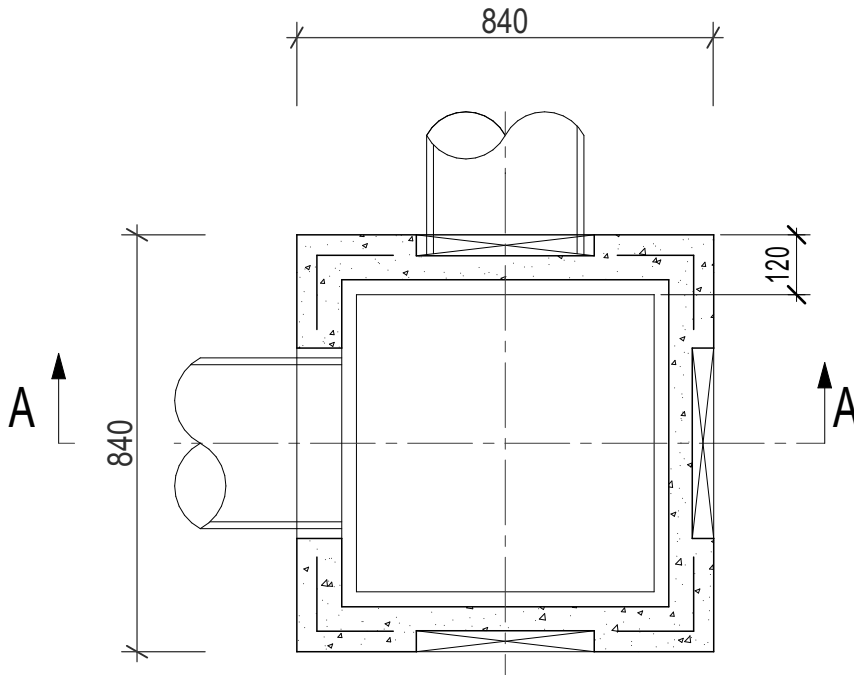

PLAN

600X600 WET CAST PITS	
DEPTH (D)	WEIGHT (kg.)
400	490
500	570
600	650
700	730
800	810
900	890
1000	970
1100	1060
1200	1140
600X600 EXTENSIONS	
HEIGHT (E)	WEIGHT (kg.)
300	245
600	490
900	730



9 COLEMANS ROAD
DANDENONG SOUTH VIC.
3175

03 9786 3111
sales@frankstonconcrete.com.au
www.frankstonconcrete.com.au

SKU 66

ALL DIMENSIONS IN MILLIMETRES (NOT TO SCALE) DRAWN: CZ
ISSUE: JUNE 2023