

900 x 900 Stormwater Pit

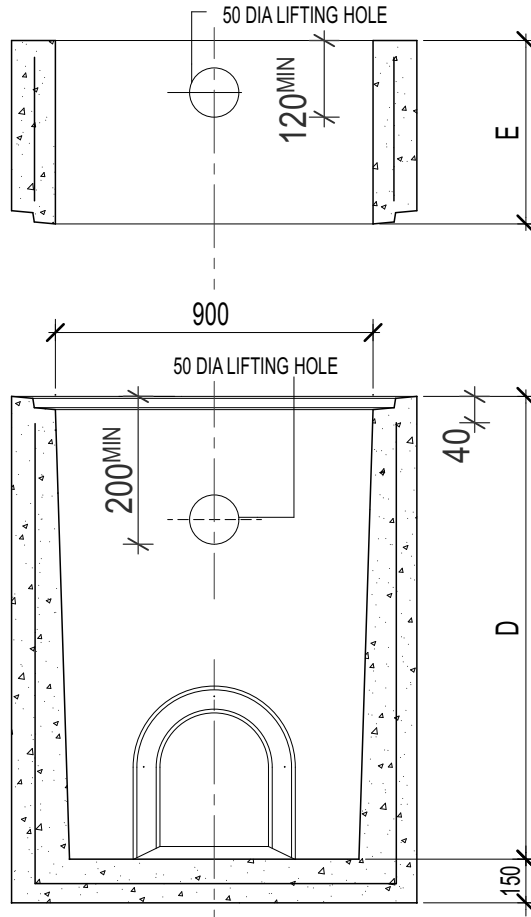

MANUFACTURE METHOD WET CAST
 CONCRETE 40Mpa
 REINFORCEMENT F72
 LIFTERS 4 x 1.3t

KNOCKOUTS
 PROVIDED ON ALL SIDES

AVAILABLE COVERS
 -CONCRETE
 -CAST IRON
 -MILD STEEL GRATING
 -HEEL SAFE GRATES
 -TERRA FIRMA

SECTION A-A

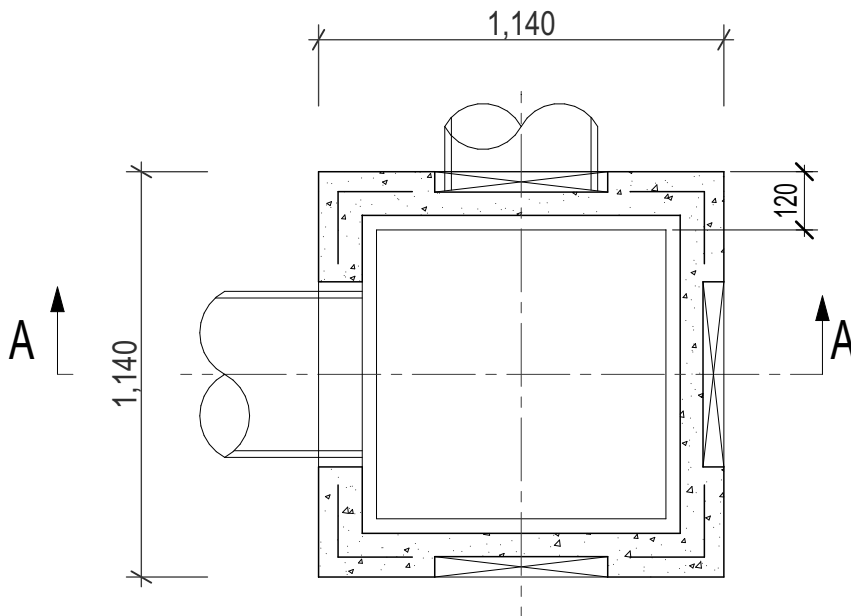

PLAN

900X900 WET CAST PITS	
DEPTH (D)	WEIGHT (kg.)
600	990
700	1100
800	1220
900	1330
1000	1450
1100	1570
1200	1680
1300	1790
1400	1900
1500	2100
1600	2200
900X900 EXTENSIONS	
DEPTH (D)	WEIGHT (kg.)
300	345
600	690
900	1030
KNOCKOUTS	
PIT DEPTH	SIZE
<700mm	420mm
>800mm	600mm

STEP IRON INSERTS TO
 AS1657-2018
 IN PIT & RISER DEPTHS
 >1000mm



9 COLEMANS ROAD
 DANDENONG SOUTH VIC.
 3175

03 9786 3111
 sales@frankstonconcrete.com.au
 www.frankstonconcrete.com.au

SKU 99

ALL DIMENSIONS IN MILLIMETRES
 (NOT TO SCALE) DRAWN: CZ
 ISSUE: JUNE 2023